PK Series Rotary Screw Air Compressor

User Manual (Controller MAM-890)

Belt Drive

PN: 97002024000074

Release: May 2024, Edition A





TABLE OF CONTENTS

SAFETY INFORMATION	1
1.1 SAFETY ALERT SYMBOLS	1
1.2 SAFETY PRECAUTIONS	1
1.3 PRESSURE.....	2
1.4 FIRE AND EXPLOSION	2
1.5 MOVING PARTS.....	2
1.6 HOT SURFACES	2
1.7 PROPER COMPRESSED AIR APPLICATIONS	2
1.8 ELECTRICAL SHOCK.....	3
GENERAL INFORMATION	4
2.1 INTRODUCTION	4
2.2 THE COMPRESSION CYCLE.....	5
2.3 COMPRESSOR LUBRICATION AND COOLING SYSTEM.....	5
2.4 COMPRESSOR DISCHARGE SYSTEM.....	5
2.5 AIREND, INLETVALVE AND FILTRATION SYSTEM	6
FLUID INFORMATION.....	6
3.1 FLUID GUIDE	6
3.2 FLUID CHANGE RECOMMENDATIONS	7
INSTALLATION	7
4.1 COMPRESSOR MOUNTING, SUPPORT AND LOCATION	7
4.2 VENTILATION AND COOLING	8
4.3 PIPING CONNECTION	8
4.4 FLUID LEVEL INSPECTION	9
4.5 ELECTRICAL	10
4.6 MOTOR ROTATION INSPECTION	10
4.7 FAN ROTATION INSPECTION	11
4.8 V-BELT INSPECTION	11
4.9 PLACING NEW BELTS ON SHEAVES.....	12
4.10 TENSIONING THE V-BELTS.....	12
OPERATION	14
5.1 ROUTINE OPERATION.....	14
5.2 CONTROLLER BUTTON	14
5.3 INDICATOR INSTRUCTIONS	17
5.4 STATUS DISPLAY AND OPERATION	17
5.5 OPERATING PARAMETERS AND MENU.....	18
5.6 USER PARAMETER VIEW AND MODIFICATION.....	18
5.7 CUSTOMER PARAMETER AND FUNCTIONS.....	19
5.8 OPERATING AUTHORIZATION AND PASSWORD.....	22
5.9 ALARM FUNCTION	22
5.10 CONTROLLER PROTECTION	23
5.11 SCHEMATIC DIAGRAM – THREE PHASE.....	25
5.12 SCHEMATIC DIAGRAM – SINGLE PHASE	26
SERVICING.....	27
6.1 FLUID CHANGE	27
6.2 AIR FILTER.....	27
6.3 FLUID FILTER	28
6.4 AIR/OIL SEPARATOR.....	28
6.5 FLUID SAMPLING PROCEDURE	28
6.6 MAINTENANCE SCHEDULE.....	28



TROUBLESHOOTING GUIDE	30
STANDARD TERMS AND CONDITIONS	33
CONTACT INFORMATION	36

Safety Information

Thank you for choosing Kaishan Compressor. Please read this instruction manual carefully before using the compressor. This manual must be kept in the safe place for future reference. Kaishan Compressor's authorized distributors provide maintenance service for PK series rotary screw compressors. A certified technician is required to ensure compressors' maintenance is safely handled. By following the instructions in this manual, the user will minimize the possibility of an accident throughout the useful life of this equipment.

1.1 SAFETY ALERT SYMBOLS

Key hazards are used throughout this manual. The level of hazards seriousness is symbolized as follows:



This symbol identifies immediate hazards which **will** result in severe personal injury, death or substantial property damage.



This symbol identifies hazards or unsafe practices which **could** result in personal injury, death or substantial property damage.



This symbol identifies immediate electrical hazards which **will** result in severe personal injury, death or substantial property damage.



This symbol identifies hazards or unsafe practices which **could** result in personal injury or substantial property damage.



This symbol identifies immediate hot surface hazards which **will** result in severe personal injury.



Identifies important installation, operation or maintenance information which is not hazard related.

1.2 SAFETY PRECAUTIONS

This manual describes the safety precautions, structure, and functions of all systems and components, as well as the operation and maintenance methods for the PK series rotary screw air compressors. The owner and operator shall read the manual carefully. Only after thorough understanding should the machine be operated for the first time. This manual gives you a general description of the mechanical and electrical systems and maintenance. However, if you have any questions about operating and maintenance of the compressor, please contact your authorized distributor or our service department personnel.

Do not modify the compressor and/or controls in any way except with written factory approval. While not specifically applicable to all types of compressors with all types of prime movers, most of the precautionary statements contained herein are applicable to most compressors and the concepts behind these statements are generally applicable to all compressors.



Failure to follow any of these precautions may result in severe personal injury, death, property damage and/or compressor damage

1.3 PRESSURE

A properly sized pressure relief valve must be installed in the discharge piping ahead (upstream) of any shutoff valve (block valve), heat exchanger, orifice, or any potential blockage point. Failure to install a pressure relief valve could result in the rupturing or explosion of some system components. Relieve all pressure internally to the compressor prior to servicing. Do not depend on check valves to hold system pressure. Do not change the pressure setting of the pressure relief valve, restrict the function of the pressure relief valve, or replace the pressure relief valve with a plug. Over pressurization of system or compressor components can occur resulting in death, severe personal injury, or property damage. Do not operate the compressor at pressures in excess of its rating. Never use plastic pipe, rubber hose, or soldered joints in any part of the compressed air system. Failure to ensure system compatibility with compressor piping is dangerous.

1.4 FIRE AND EXPLOSION

Clean up any spills of lubricant or combustible liquid immediately. Keep sparks and flame away from the compressor. Do not permit smoking during servicing, such as checking or adding fluid. Wipe down spills immediately using industrial cleaner as required. Do not use flammable material for cleaning purposes. Do not operate the compressor in a hazardous environment unless the compressor has been specially designed for that environment. Wear personal protective equipment including safety goggles and clothing while servicing the compressor. Never use a flammable or toxic solvent for cleaning the air filter or any parts.

1.5 MOVING PARTS

Keep hands, arms and cloths away from the coupling and fans of the compressor. Do not remove any guards or cabinet panels or attempt to service any compressor part while the compressor is operating.

1.6 HOT SURFACES

Do not touch any hot surface and parts during the compressor's operation. Keep all body parts away from steel tubing, air end, oil-cooler and after-cooler. Wear personal protective equipment including gloves while servicing the compressor.

1.7 PROPER COMPRESSED AIR APPLICATIONS

Air from this compressor will cause severe injury or death if used for breathing or food processing. Air used for those processes must meet OSHA and applicable industry.

regulations. This compressor is designed for use in the compression of normal atmospheric air only. No other gases, vapors or fumes should be exposed to the compressor intake, nor processed through the compressor. Keep personnel away from the compressed air discharge. Use compressed air for cleaning purposes only with effective chip guarding and personal protective equipment which meet OSHA standard and/or any federal, state, local codes, standard and regulation.

1.8 ELECTRICAL SHOCK

Never start the compressor unless it is safe to do so. Do not attempt to operate the compressor with a known unsafe condition. Tag the compressor and render it inoperative by disconnecting and locking out all power at the source or otherwise disabling its prime mover so others who may not know of the unsafe condition cannot attempt to operate it until the condition is corrected. Install, use and operate the compressor only in full compliance with all pertinent OSHA regulations and/or any applicable Federal, State, and Local codes, standards and regulations. Never assume it is safe to work on the compressor because it is not operating. Many installations have automatic start/stop controls, and the compressor may start at any time.

- Follow all maintenance procedures and check all safety devices on schedule.



NOTICE

- Use the correct compressor fluid at all time
- Do not rely on the discharge check valve to isolate the compressed air service line
- Keep panels closed at all times, and stay away from hot surfaces to prevent hazards



NOTICE

These instructions, precautions and descriptions cover PK series air compressors. As a service to our customers, we often modify or construct packages to the customer's specifications. This manual may not be appropriate in those cases.

Every effort has been taken to ensure complete and correct instructions have been included in this manual. However, possible product updates and changes may have occurred since printing this manual. Kaishan Compressor USA reserves the right to change specifications without incurring any obligation for equipment previously or subsequently sold.

General Information

2.1 INTRODUCTION

The PK compressor is a V-belt driven, single stage, positive displacement, fluid-flooded rotary screw. All components are assembled on a structural steel base. The control panel is located in front of the enclosure door panel. A complete package consists of the following:

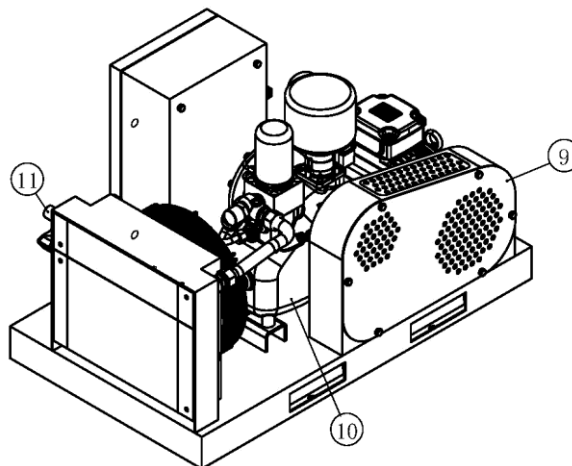
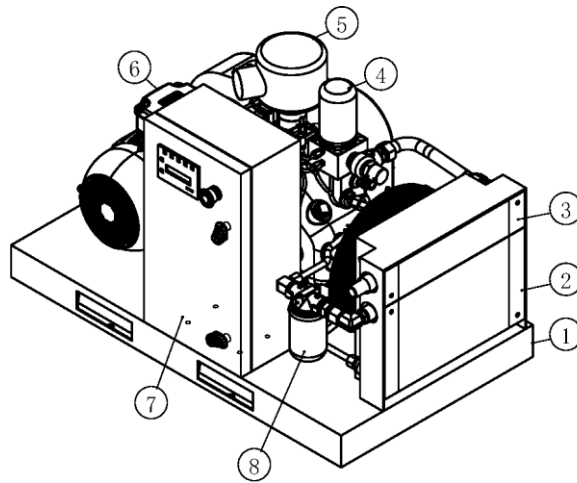

- | | |
|--------------------------------------|-------------------------|
| 1. Base | 2. Fluid cooling system |
| 3. Air cooling system | 4. Discharge system |
| 5. Inlet valve and filtration system | 6. Motor |
| 7. Electrical enclosure | 8. Lubrication system |
| 9. Belt and guard | 10. Airend |
| 11. Discharge port | |

Air tank is one of the optional features for all compressors.



Dismantling the compressor's enclosure may void its warranty.

NOTICE!

2.2 THE COMPRESSION CYCLE

The airend assembly includes two portions of airend and airend casing. Airend contains of two rotors; Male and Female rotors. They are constantly and precisely meshed and housed in the cylinder with two parallel adjoining bores. All parts are machined to exact tolerances. The rotors provide positive-displacement internal compression smoothly and without surging. As the rotors rotate, air is drawn into the cylinder through the inlet port. A volume of air is filled and trapped as the rotor lobes pass the inlet port in the cylinders. Compression occurs as the male rotor rolls into the female flute, progressively reducing the space thereby raising the pressure.

Compression continues until the lobe and flute pass the discharge port.

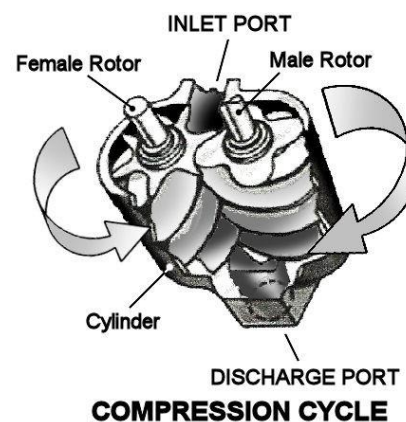

2.3 COMPRESSOR LUBRICATION AND COOLING SYSTEM

The lubrication and cooling system consists of an axial fan, fluid-cooler, after-cooler, thermal valve and fluid filter. High pressure forces the lubricant through a series of direction changes in the airend casing where it is separated from the air. The fluid is then delivered to the thermal valve and fluid-cooler. Cooled fluid will be filtered before being re-injected back into the compressor. As the discharge temperature rises and exceed the temperature setting of cooling fan start-up, ambient air is being forced through the cooler fins by the axial fan, which cools the fluid and compressed air in the cooler tubes. Cooler fins must be kept clean at all times.

2.4 COMPRESSOR DISCHARGE SYSTEM

Air/fluid mixture has been forced into airend cast casing after compression. The airend cast casing has two basic functions:

- It acts as a primary fluid separator.
- It serves as the compressor fluid sump.

The compressed air/fluid mixture enters the casing and is directed against the internal baffle, causing large droplets of fluid to form and fall to the bottom of casing. Fluid collected in the casing will then be returned to the airend due to the pressure differential.

The sight glass enables the operator to visually monitor the reservoir fluid level. Fluid is added to the airend cast casing by removing the fluid filling cap after all system pressure is relieved.

2.5 AIREND, INLETVALVE AND FILTRATION SYSTEM

The compressor inlet system consists of an air filter, inlet valve, & **SKK** airend. The inlet valve controls the air intake volume. It also acts as the check valve to prevent the reverse pressure and rotation when compressor is shutting down.

①	Fluid Fill Port
②	Airend casing
③	Sight Glass
④	Pressure gauge

①	Air filter
②	Inlet valve
③	Airend
④	Airend casing

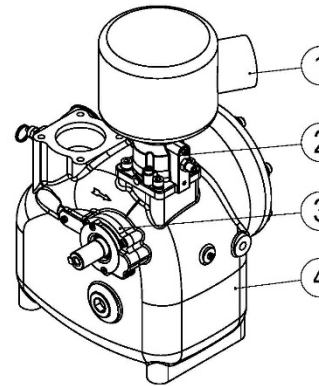

Fluid Information

3.1 FLUID GUIDE

PK compressors are filled & tested with Kaishan lubricant. Refer the following figure for filler port, sight glass, pressure gauge and drain valve location on the reservoir. The compressor is filled with the manufacturer's recommended quantity of Kaishan fluid. Inspection of the reservoir fluid level during installation or operation is recommended.

⑤ Fluid Drain Valve

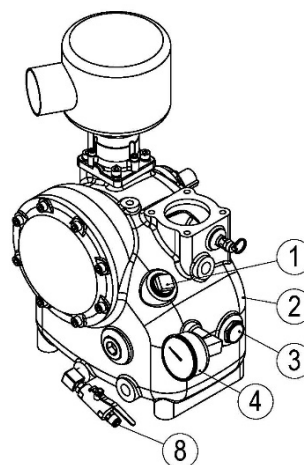

Do not use different fluids. Using different fluids will void compressor's warranty.

3.2 FLUID CHANGE RECOMMENDATIONS

LUBRICANT	FLUID CHANGE	REMARK
KTL8000	Every 8,000 hours or as indicated by sampling report	Standard factory fill fluid Sampling every 2000 hours is required
KTL4000 FG	Every 4,000 hours or as indicated by sampling report	FDA & NSF approved Halal certified

Installation

4.1 COMPRESSOR MOUNTING, SUPPORT AND LOCATION

All models are intended for indoor installation. The compressor should be located on a flat surface in a clean, well-lit and well-ventilated area. The location must have sufficient access for maintenance equipment and sufficient clearance around the compressor is recommended for daily inspection and easy access to all compressor components. The area must have

sufficient lighting for technicians to safely operate the compressor as well as perform maintenance work. The location should be free from standing water.

The compressor's base must be installed on a level surface that can support the gross dead weight of the machine. A stationary compressor will prevent accidents such as broken piping or electrical connections.



Removal or paint over of safety labels will be a safety hazard. This could result in personal injury or property damage. Warning signs and labels should be conspicuous and on a bright legible surface. Do not remove any warning, caution or instructional material attached with unit.

4.2 VENTILATION AND COOLING

Ambient temperature should not exceed 40°C (104°F). High ambient temperatures may result in high air temperature shutdown.



NOTICE!

Do not install and operate the compressor if the ambient temperature is below 2°C (35°F). Severe ambient modifications must be installed with the unit for lower ambient temperatures.

The compressor air inlet must be located in the opposite direction to other compressors or heat generating equipment. The object is to avoid hot air being drawn into the system. Do not block the exhaust air from cooler or fan. Hot exhaust air must be vented outside through a duct to prevent high ambient room temperature. The compressor room must be properly ventilated to avoid compressor high temperature shutdown.



Maintain clean & fresh air, dust free, metal particle free and chemical vapor free in the compressor's room. Housing the compressor within a poorly ventilated enclosure will cause higher operating temperature.



Under no circumstances should a compressor be installed in an area exposed to toxic, volatile or corrosive atmosphere, nor should toxic, volatile or corrosive agents be stored near the compressor.

4.3 PIPING CONNECTION

Before installation, review the complete air systems layout, which includes compressor(s), receiver tank, dryer (if applicable), line filter(if applicable), pipe size, water drain and isolator valves. Never join pipes or fittings by soldering. Never use PVC pipe or non-genuine rubber hose in the air system. Use flexible connections to prevent pipe load from being transmitted

to the compressor. Never use a different pipe size other than the manufacturer specification for the compressor unit.

A service line shut off valve must be installed after the compressor air outlet connection with a pressure relief valve installed to release compressed air to the atmosphere. For a single compressor and air receiver tank, manual shut off valves are typically being installed. A union connector must be installed after the ball valve (quarter turn, shut off valve) at the compressed air outlet. This will allow unit isolation for maintenance.



Make sure system pressure is relieved by confirming that sump pressure gauge is reading zero prior to servicing. Failure to relieve system pressure could result in death or serious injury and property damage.

A receiver tank should be installed if compressed air demands fluctuate. Service line piping is recommended to be sized to match the compressor's discharge connector. All piping & fittings should be rated to withstand greater pressure than the discharge pressure. Isolation valves & drain valves are installed to isolate the compressor when service is required. These valves should have water drip legs with the drain direction facing downward to the floor. Piping should all line up properly with an adequate loop radius or bend radius given for easy installation and to prevent bending stress, flow restriction and damage due to thermal expansion. Piping support brackets must be mounted independent of the compressor and motor. This will avoid damage caused by vibration.

Pressure relief valves are sized to protect the system. Never change the pressure setting or tamper with the valve. Only the valve manufacturer and their authorized representatives are allowed to make such changes.



Pressure relief valves are used to protect system integrity in accordance with safety standards. Failure to provide properly sized valves will result in death or serious injury.

Pressure relief valves are installed prior to any potential blockage point such as shutoff valves, heat exchangers and discharge silencers. Ideally, the valve should be threaded directly into the pressure point it is sensing, not connected with tubing or pipe. Always direct discharge from relief valves to a safe area away from personnel.

4.4 FLUID LEVEL INSPECTION

Inspect the fluid level when the compressor is in shut down mode to make sure fluid has not leaked from the unit during transport. Fluid level is indicated on the airend casing sight glass. When the compressor is running, the level should be visible on the sight glass.

4.5 ELECTRICAL

Before installation, the electrical supply should be checked for adequate wire size and capacity. User must comply with national & local electrical codes. The codes specify the surrounding clearance requirement for the electrical panel. Wiring work should be undertaken only by a qualified electrician in compliance with OSHA, national or local electrical code. PK compressor includes wiring diagrams for user reference. Refer to the electrical control schematic in the parts manual for wiring diagrams. Genuine fused disconnect switch or circuit breaker should be purchased from the manufacturer. Any unreasonable voltage imbalance (5%) between phases must be eliminated and low voltage problems must be corrected to prevent excessive current draw. Air compressors must be grounded in accordance with applicable codes, regulations and requirements.



Kaishan Compressor would like to emphasize the importance of providing adequate grounding for air compressors. The common practice of grounding units to a building's structural steel may not provide adequate grounding protection, as paint and corrosion build-up may exist.



All electrical supply cables must be adequately sized to prevent overheating due to current draw.



Enclosure panels and drive grille must be fastened in place before starting the compressor and never removed before lock out / tag out of the main power supply.

A starter hole is provided for an incoming power connection. If a different location for the starter hole is needed, the certified technician must make sure to keep control box clean after the hole is created. The original hole must be capped if another hole is used. Inspect incoming voltage to match the compressor's specification. Inspect motor starter and overload heater sizes. Check electrical connections for tightness and cleanliness.

4.6 MOTOR ROTATION INSPECTION

Motor rotation must be checked after the wiring has been installed. Operating the compressor in incorrect rotation will result in severe damage to the compressor and warranty coverage will be voided. Motor rotation can be viewed through the opening in the drive grille. The drive motor end of the compressor is marked with an arrow noting the proper rotation.

To inspect rotors rotation, pull out the "EMERGENCY STOP" button and press once, quickly press the "START" and "STOP" button in sequence, allowing the motor to turn 2 or 3 revolutions. Observe the drive shaft for correct direction. If reverse rotation is observed,

disconnect the power supply, reverse power input leads at the motor starter. Recheck for proper rotation.

4.7 FAN ROTATION INSPECTION

Fan motor rotation should be inspected. PK compressors use an axial fan for cooling. The fan must rotate in the direction indicated by the arrow.



Always inspect fan rotation through the fan guard. Never assume the fan rotation is correct based on the induced air flow across the coolers. However, incorrect rotation will cause high discharge temperature.

NOTICE!

4.8 V-BELT INSPECTION

Ensure the pulley and sheave are properly aligned and the motor anchor screws are adequately retightened prior to restarting the compressor.

Remove belt guard and inspect belt condition. Check sheave grooves for nicks, scratches and correct dimensions.

Thoroughly inspect the bore of the sheave and surface of the bushing. Any paint, dirt, metal chips, fluid or grease **MUST** be removed. It is important to note that sheave condition and alignment are vital to V-belt life and performance. Use thrust bolt to properly adjust pulley and sheave alignment. Sheaves should be carefully checked whenever V-belts are replaced. Focus attention on the following conditions:

- A. Worn groove sidewalls.
- B. Shiny sheave groove bottom, a sign of “bottoming” out of loosening wedging action.
- C. Wobbling sheaves.
- D. Damaged sheaves.

To ensure proper belt installation, check the following (Dotted line is correct alignment):

Figure A shows drive and driven shafts are not align.

Figure B shows the correct location of sheaves, belts are inline and parallel with each other.

Figure C shows sheaves locations are not inline.

Figure D shows driven shaft has angular misalignment.



Figure A



Figure B



Figure C



Figure D



Worn sheaves can seriously shorten the life of V-belts.

NOTICE!

4.9 PLACING NEW BELTS ON SHEAVES

Shorten the center distance of the drive until the belts can be put on the sheaves without forcing. Forcing the belts can cause internal injury to the belts.

4.10 TENSIONING THE V-BELTS

With the sheaves moved to a minimum center distance for belt removal as described above, the new belts can be easily placed over the sheaves and dropped into the grooves. (If the motor base has been moved, readjust it to provide slack for easy installation)

Check belt tension should be occasionally, especially if looseness is suspected. New belts must also be properly tensioned upon installation. Units are equipped with a belt tensioning bolt, when tighten up, it pulls the motor away from the airend. Belt tensioning can be achieved by loosening the motor anchor screws, loosening the thrust bolt, tightening belt tensioning bolt and retightening the motor anchor screws.

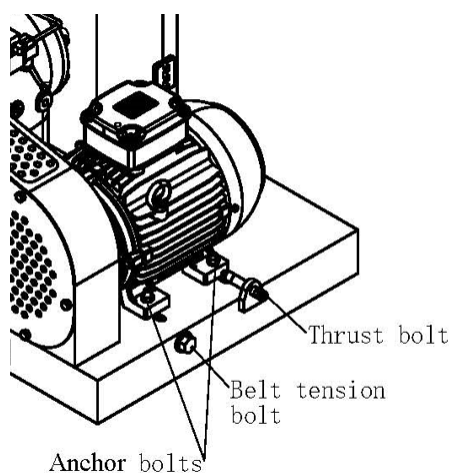

Please use the table below, belt installation and adjustment allowance for belts installation.

INSTALLATION & ADJUSTMENT ALLOWANCE					
BELT STD. LENGTH (mm)	INSTAL. ALLOWANCE				ADJUST. ALLOWANCE (mm)
	SPZ Z	SPA A	SPB B	SPC C	
410-530	20	25	30	50	5
530-840					10
850-1160					5
1170-1500					20
1510-1830					25
1840-2170					30
2180-2830					40



Only use Kaishan Genuine V-Belt for new belt installation

NOTICE!

Operation

5.1 ROUTINE OPERATION



Provisions should be made to have the instruction manual readily available to the operator and maintenance personnel. If, for any reason, any parts of the manual become illegible or if the manual is lost, have it replaced immediately. The instruction manual should be read periodically to refresh one's memory. This may prevent a serious accident.

Before the compressor start up, inspect fluid level in reservoir. After start up, observe the control panel screen for operation status. Ensure the compressor is running at its optimum level.

Close the service valve to plant air distribution system. Allow pressure to build up within the reservoir until the compressor fully unloads. Press the stop button.



NOTICE

Always close the service valve when compressor is not being used. It prevents back pressure from the service line and avoids leakage due to check valve failure.



NOTICE

Emergency shutdown. Press the emergency stop button or pull the circuit breaker at the main power terminal.

5.2 CONTROLLER BUTTON

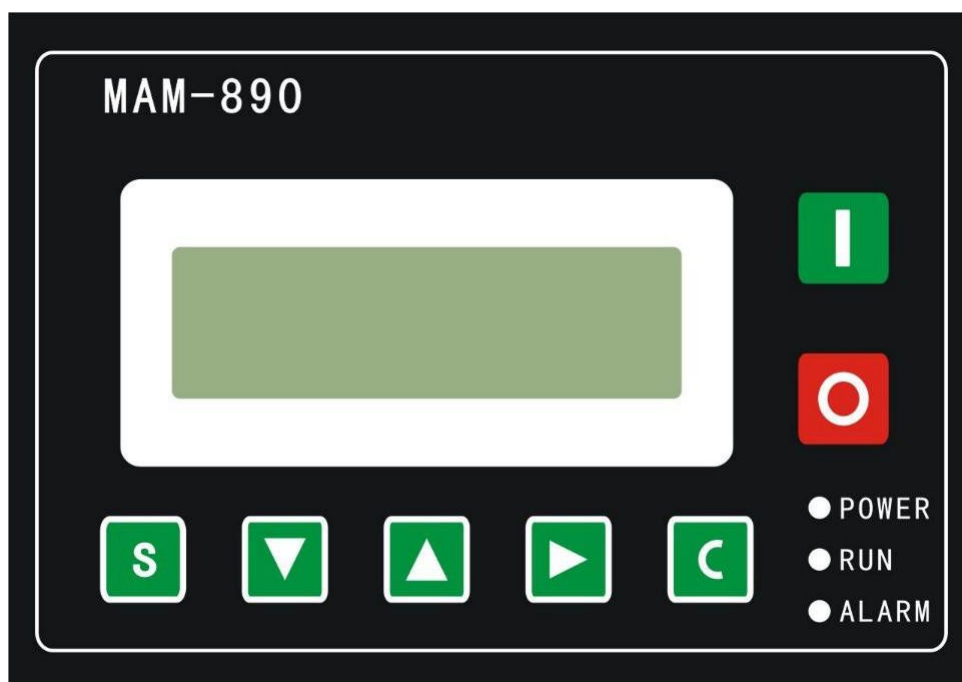

 — Start Button:

1. When compressor is at stop status, press this button to start the compressor.
2. When compressor is set as master (No.1) in block mode, press this button to start the compressor and activate block mode function at the same time.

 — Stop Button:

1. When the compressor is at running status, press this button to stop the compressor.
2. When compressor is set as master (No.1) in block mode, press this button to stop compressor and block mode function as well.
3. When compressor is at stop status, long press this button to display software edition.

 — Set Button /Loading / unloading Button:

1. When the compressor is at running status, press this button to load, unload.
2. When the compressor is at setting mode, press this button after modification to confirm and save the modified data.

 — Move down button / Decreasing button:

1. When viewing the menu, press this button to move downward the cursor.
2. When modifying data, press this button to decrease the data at current position.

 — Move up button/Increasing button:

1. When viewing the menu, press this button to move upward the cursor.
2. When modifying data, press this button to increase the data at current position.



—Shift button /Enter button:

1. When modifying data, press this button to move to the next data bit;
2. When select menu, press this button to switch to submenu. If no submenu available, the controller will shift to data setting mode.



—Return button / Reset button:

1. When modifying data, press this button to exist data setting mode.
2. When viewing the menu, press this button to return to previous menu.
3. When the controller is at failure stop status, long press this button to reset

5.3 Indicator instructions

Power Indicator: Indicator on when controller is energized. Run indicator: Indicator is on when motor is running.

Alarm indicator: Indicator is blinking when alarming; indicator on when fail to stop; indicator off when error is cleared

5.4 Status Display and Operation

The display screen will show as below after power on:

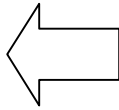
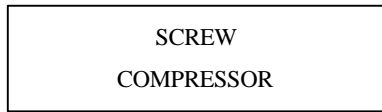

After power on, show this menu

After 5 seconds, the main page will show up as:

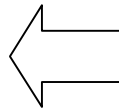
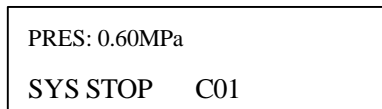

Main menu

Press , the main menu will show up as:

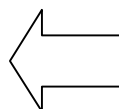
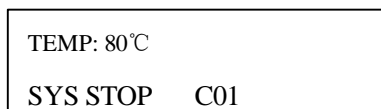

Main menu

Press  to enter into Selection Menu:

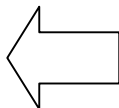
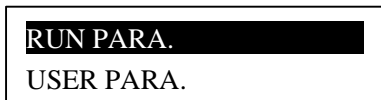

Level 1 menu

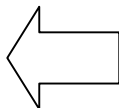
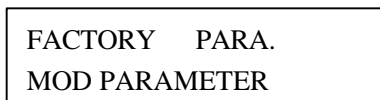



Level 1 menu



5.5 Operating parameters and Menu

Press  to move the cursor to "RUN PARAMETER", then press  to switch to the secondary menu:

MOTOR(A) A-0100
B-0100 C-0100

Press  to check the specific parameter. Such as viewing "FAN CUR", "RUN TIME", "LOAD TIME" and so on. Press the  to return to the previous menu or the main menu. If no operation at the current menu for 60 Seconds, controller will automatically return to the main menu.

5.6 User Parameter View and Modification

In first menu, press the  and  to move the cursor to the "USER PARA." item, press the  to switch to the following menu:

LOAD PRES:



00.65MPa

UNLOAD PRES:

00.65MPa

In this menu, press  to switch to the following menu which requires a user password input.

PASSWORD:0***

In this menu, the first data bit of password started blinking, press  or  to modify the first bit of password, Press the , move the cursor to the next data bit, modify the second data of password. In accordance with the above, modify the third and fourth data of

password in sequence. Press **S** to confirm the input data and the menu will switch to the following menu after verification:

The upper right corner with " * " indicates the system verification of the password

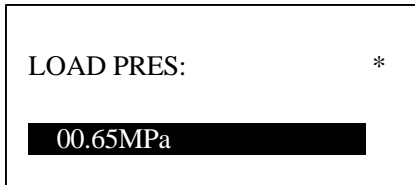

In the menu above, press **▶**, the first data of loading pressure starts to blink, user can press **▲** or **▼** to modify the present data in accordance with the above method. Press **▶** to move to next data bit and modify to the target data in sequence. When finished, press **S** to confirm and save the data. The controller prompt sends out a short voice to tip the completion of parameter set.

5.7 Customer Parameter and Functions

Parameters	Preset Value	Functions
LOAD P.	00.60MPa	1, In AUTO LOADING, compressor will load if pressure is below this set data 2. In STANDBY mode, compressor will start if the pressure is below this set data
UNLOAD P.	00.80Mpa	1. Compressor will unload automatically if air pressure is above this set data 2. This data should be set above LOAD P, also should be set below ULD LIM P
FAN START T	0080°C	Fan starts when discharge temperature is above the data set.
FAN STOP T	0070°C	Fan stops when discharge temperature is below the data set.
MOTOR DELAY	0008S	Set the master start time, record time when master is activated, controller will not start overload protection during this time to avoid stopping the master by impulse starting current
STAR DELAY	0006S	Time from star start to delta start.
LOAD DELAY	0002S	Unloading in this set time after enter delta running
UNLOAD DELAY	0600S	When unloading continuously, compressor will automatically stop and enter to standby status if over this set time



Parameters	Preset Value	Functions
STOP DELAY	0010S	For NORMAL STOP operation, compressor will stop after it continuously unloading over this set time
START DELAY	0100S	Machine can be restarted only over this set time at any case (after NORMAL STOP, STANDBY or FAILURE STOP)
ON/OFF MODE	LOCAL /REMOTE	1. When set as LOCAL, only the button on the controller can turn on and turn off the machine. 2. When set as REMOTE mode, both the button on the controller and the remote-control button can turn on and off the machine;
LOAD MODE	AUTO /MANU	1. When set as the MANU: only when the pressure is above “unloading pressure”, compressor will unload automatically. For any other case, the Loading/Unloading function can only be executed by pressing “loading /unloading” key. 2. When set as AUTO, the loading/ unloading function can be executed by the fluctuation of air pressure automatically
COM MODE	PROHIBIT /COMP. /BLOCK	1. When set as PROHIBIT, the communication function is invalid. 2. When set as COMP., compressor function as a slave and is able to communicate with computer or DCS 3. When set as BLOCK, compressor can net control
COM ADDRESS	0001	Set the communication ADD in block mode or when communicate with monitoring center. This ADD is unique for every controller in net
TURN TIME	0099 Hours	When master pressure is between BLOCK LOAD P and BLOCK UNLOAD P, master determine slave work alternatively over this set time.
BLK NUMER	0000	Number of air compressors in block net
BLK MIN	00.65MPa	In BLOCK, one compressor will start or load when pressure is below this set data
BLK MAX	00.75MPa	In BLOCK mode, one compressor will stop or unload when pressure is above this set data
BLK DELAY	0050S	In BLOCK mode, when master sends two commands continuously, second command signal delays for this set data.
OIL FILTER	0000H	Record total running time of oil filter, if changing new oil filter, the data should be reset by manual operation.
O/A SEPARATOR	0000H	Record total running time of O/A separator. If changing new O/A separator, the data should be reset by manual operation

Parameters	Preset Value	Functions
AIR FILTER	0000H	Record total running time of air filter. If changing new air filter, the data should be reset by manual operation
LUBE	0000H	Record total running time of lube. If changing lubricate, the data should be reset by manual operation
GREASE	0000H	Record total running time of grease. If changing new grease, the data should be reset by manual operation
BELT	0000H	Record total running time of belt. If changing new belt, the data should be reset by manual operation
OIL FILTER	9999H	1. Alarm prompts when total running time of oil filter is above the set data. 2. Set this data to “0” to clear oil filter running time
O/A SEPARATOR	9999H	1. Alarm prompts when total running time of O/A separator is above the set data. 2. Set this data to “0” to clear O/A separator running time
AIR FILTER	9999H	1. Alarm prompts when total running time of air filter is above the set data. 2. Set this data to “0” to clear air filter running time
LUB	9999H	1. Alarm prompts when total running time of lubricate is above the set data. 2. Set this data to “0” to clear lubricate running time.
GREASE	9999H	1. Alarm prompts when total running time of grease is above the set data. 2. Set this data to “0” to clear grease running time
BELT	9999H	1. Alarm prompts when total running time of belt is above the set data. 2. Set this data to “0” to clear belt running time.
LANGUAGE SEL	ENGLISH /CHINESE	1. Set to “EN”, Display in English 2. Set to “CH”, Display in Chinese
USER PASSWORD	9999	User could modify the user password by old user password or factory password
START MODE	STAR-DELTA / DIRECT	Set as star-delta, compressor starts through the process from star to delta; Set as direct start, compressor starts directly and no star-delta process. (see the two schematic diagrams for reference)

5.8 Operating Authorization and Password

Controller provides multiple passwords and access management. According to different levels of passwords, controller provides different levels of operating authorization, details as following:

User operation password: 9999

Permissions: allows to modify the LOADING P, UNLOADING P, FAN START T, FAN START T, ON/OFF MODE, LOAD MODE, COM MODE, COM ADD and BLOCKING MODE.

5.9 Alarm Function

1. Air Filter Alarm

The monitor displays AIR LIFE END when the running time of the air filter exhausts.

2. Oil Filter Alarm

The text displays OIL LIFE END when running time of the oil filter exhausts.

3. O/A separator Alarm

The text displays “O/A LIFE END” when running time of the O/A separator exhausts.

4. Lubricating Oil Alarm

The text displays LUBE LIFE END when running time of the lubricating exhausts.

5. Grease Alarm

The text displays GREASE LIFE END when running time of the grease exhausts.

6. Belt Alarm

The text displays BELT LIFE END when running time of the belt exhausts.

7. High Discharge Air Temperature Alarm

The text display HIGH TEMPERATURE when controller detects the discharge air temperature higher than ALARM T set data in MANUFACTORY PARA.

5.10 Controller protection

1. Motor protection

MAM-890 air compressor controller provides overload, open phase, current unbalance protection for motor

Failure	Display
Overload	Display “MASTER/FAN OVER LOAD”
Open phase	Display “MASTER OPEN PHASE”
Unbalance	Display “MASTER-UNBLANCE”

2. High Discharge Air Temperature

When discharge air temperature is above the high limit of set temperature, the controller will send out the alarm to shut down the machine and This fault displays HIGHT T.

3. Air Compressor Non-reversing

When compressor stops and three phases sequence is not in order, THIS FAULT displays PHASE REVERSAL, and the controller cannot start the motor. Change the position of any arbitrary two-phase power lines and check the rotation of motor.

4. High Pressure

When the discharge air pressure is above the MAX LIM P, the controller will send out the alarm to shut down the machine and THIS FAULT displays HIGH P.

5. Sensor Failure

When pressure sensor or temperature sensor is disconnected, the controller will send out the alarm to shut down the machine and THIS FAULT displays **SENSOR FAULT.

6. Low Temperature

When discharge air temperature is below LOW T PRO in manufacturing parameter, THIS FAULT displays P SENSOR FAULT two minutes after compressor turns on, the controller will send out the alarm to shut down the machine.



5.11 Schematic Diagram – three phase

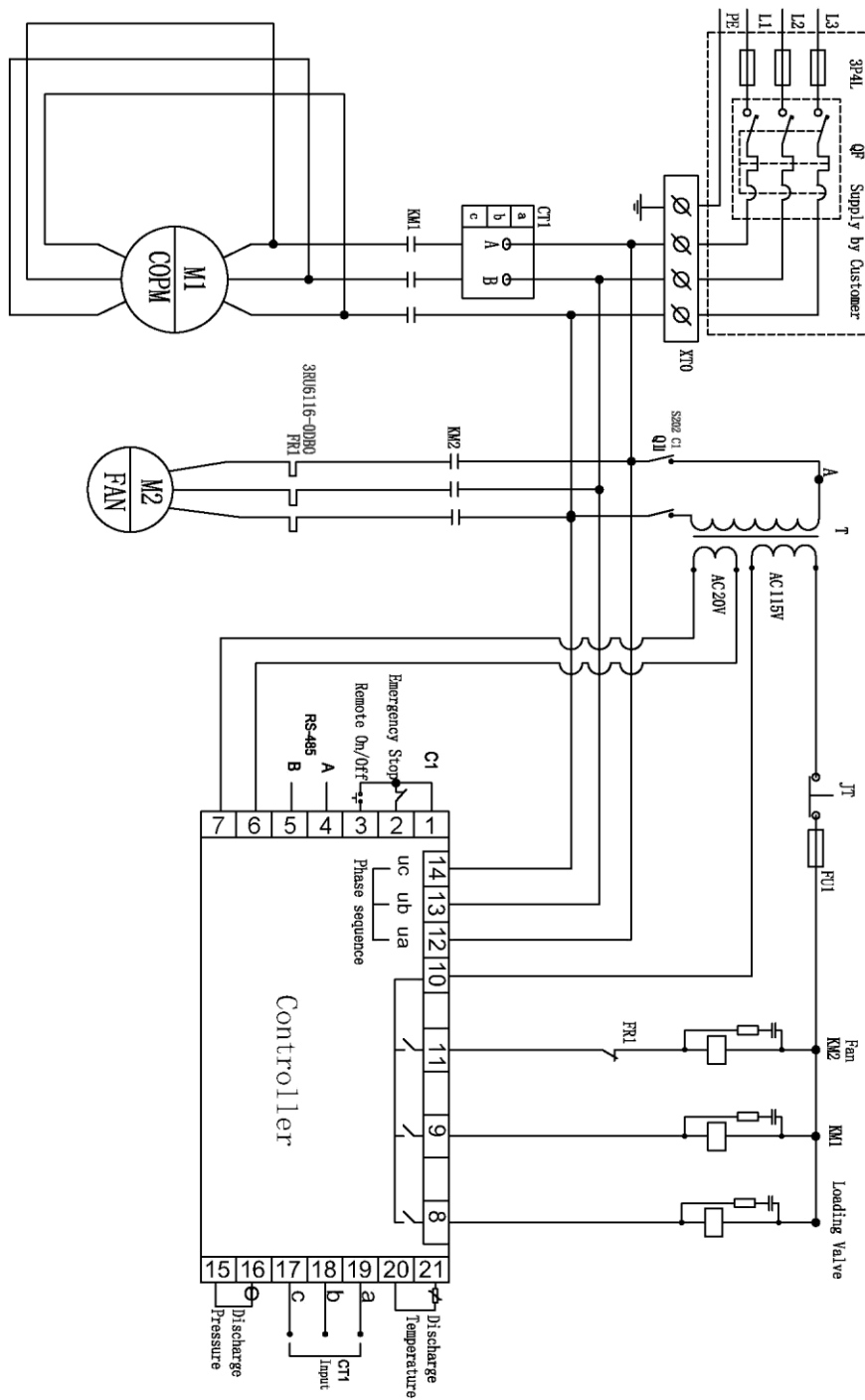

5.12 Schematic Diagram – single phase

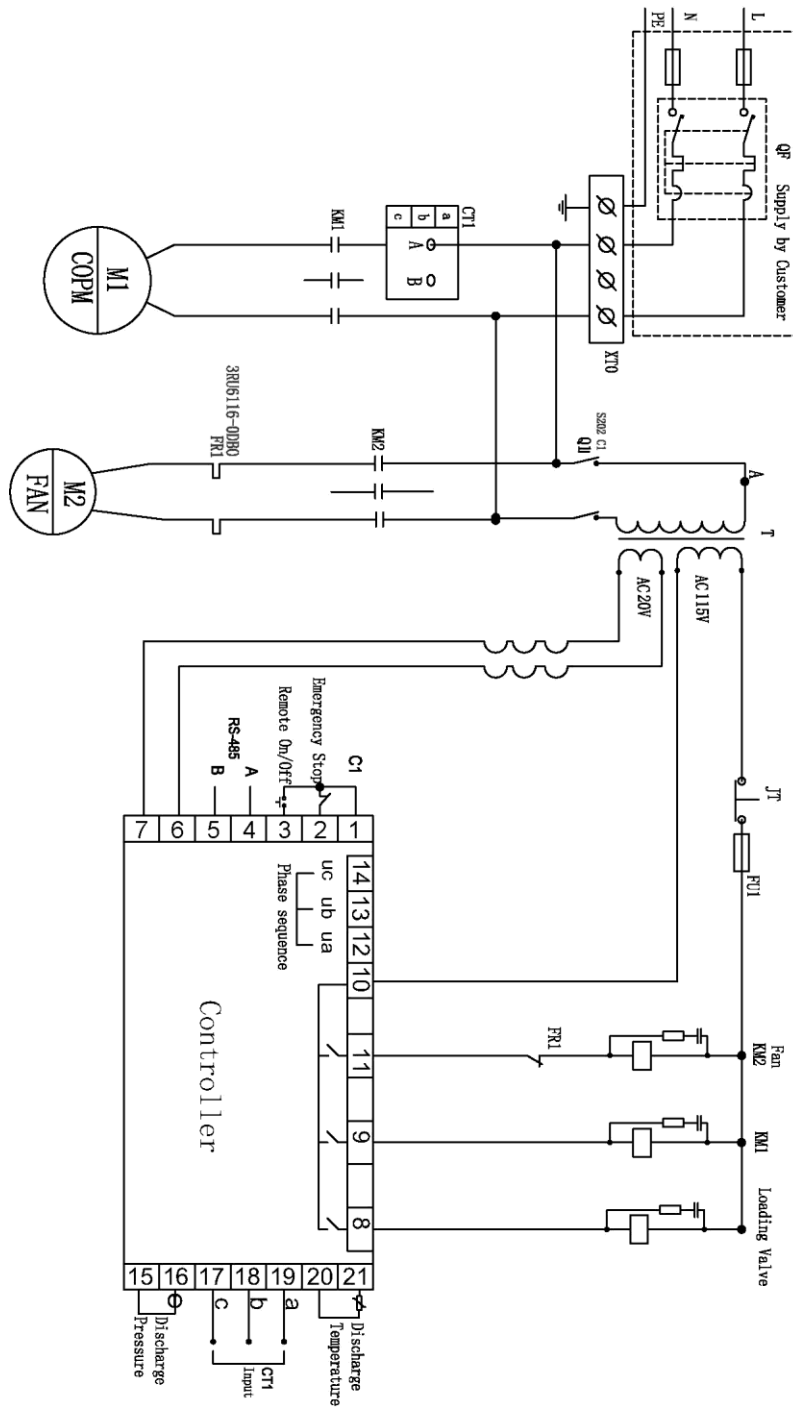

Servicing

PK compressors require the minimum amount of inspection and maintenance. The controller and indicator alert the operator to perform required maintenance or repair unit problems.

6.1 FLUID CHANGE

Use the following procedure to drain and replace the compressor fluid.

- i. Run the compressor for a while to warm the lubricant.
- ii. Stop the compressor, power off.
- iii. Open drain valve on airend casing and fluid cooler, plug in drain hose.
- iv. Drain oil in a container or waste dedicated pipeline
- v. Close drain valve
- vi. Remove oil filter and pre-filter, drain oil, replace with a new part.
- vii. Remove the plug from the fluid fill port and refill with the appropriate amount of KTL8000 fluid. Refit and tighten the plug.
- viii. Power on and start up compressor for a few minutes, shut down.
- ix. Unscrew the plug from the fluid fill port and refill to the adequate level

6.2 AIR FILTER

The standard Kaishan air filter is a single stage, dry type element. Air filter maintenance should be performed when the maintenance gauge shows red with the compressor running full load, or every 2,000 hours, or once a year, whichever comes first.

Daily cleaning of the filter element is common in dirty conditions. If dirty conditions exist, it is advisable to relocate the intake air to an outside source. Each time the filter is serviced, inspect the filtered air side of the air cleaner canister and the suction manifold for dirt. If dirt is found, determine the cause and correct. Always make sure all gaskets, threaded connections, flange connections, and hose connections between the air filter and air compressor-are airtight. Dirty filters result in reduced airflow and can distort the element and allow dirt to bypass the filter element.



NOTICE

Intake filtration equipment supplied from the factory may not be adequate for extremely dirty applications or some forms of dust or vapors. It is the customer's responsibility to provide adequate filtration for those conditions. Warranty will be voided if inadequate filtration causes a failure.

6.3 FLUID FILTER

The fluid filter is a spin on, full flow unit. Replacement of the filter requires spinning off the cartridge and replacing it with a new one. The initial filter change should occur after the first 500 hours of operation. During normal service, the filter cartridge should be replaced under the following conditions, whichever occurs first:

- ◆ As indicated by the fluid filter maintenance indicator when the fluid is at normal operating temperature
- ◆ Every 2,000 hours
- ◆ Every fluid change

6.4 AIR/OIL SEPARATOR

The air/oil separator is a coalescent filter element. Replacement of standard type separator requires unbolting and lifting the separator cover and replacing it with a new one. The air/oil separator should be replaced as indicated in the maintenance schedule or as follows:

- ◆ If excessive fluid carryover is observed.
- ◆ 2,000 hours MAX

6.5 FLUID SAMPLING PROCEDURE

The following is a sampling procedure for oil sump without fixed sampling hardware installed. Check the pressure gauge reading on reservoir and wait until there is no pressure in system. The oil sample is collected by gravity drain into the sample bottle.

- i. Stop the compressor, power off.
- ii. Remove drain plug. Drain any free water that may accumulate at bottom *before* filling sample bottle.
- iii. Avoid overfilling the sample bottle. Fill sample bottle up to above 80% but below the threads of the bottle. Seal the bottle tightly, wipe clean.
- iv. Wipe excess contamination from sample area.

Pre-label or label sample bottle immediately after filling to avoid mix-ups. Make sure bottles are labelled with full sample details.

6.6 MAINTENANCE SCHEDULE

This Schedule is intended to be used as a guideline only. Depending on the specific operating conditions of your PK compressor, maintenance requirements may vary. The

instructions in this section will give more details about determining when specific service should be performed.

First 500 hours	Change fluid filter and check fluid level
Every 500 hours	<ul style="list-style-type: none"> Drain water from airend casing. Check fluid level Clean air filter Clean after-cooler fins. Check for loose fluid and air tubing, electrical wiring connection.
Every 2000 hours	<ul style="list-style-type: none"> Check belt tension Check safety valve Replace fluid filter Replace air filter. Perform fluid sampling. Replace air/oil separator element
Every 8000 hours	<ul style="list-style-type: none"> Replace belts. Replace fluid.

Troubleshooting Guide

Information below is a troubleshooting guideline; it describes symptoms and possible cause. Do not assume that these are the only faulty condition that may occur.

Table 7-1: TROUBLE SHOOTING GUIDE		
Symptom	Possible Cause	Solution
Fail to Start	Power failure	Check power supply to the unit
	Low incoming voltage	Check voltage and power source, or contact local power company.
	Fuse blown	Replace Fuse
	Contactor fault	Check the switch for malfunction or loose connection.
	Emergency button	Reset emergency button
	Motor starter overload tripped	Check motor starter wiring before removing motor. Remove motor and have tested at motor manufacturer repair center.
	Loose wire connections	Check all wiring terminals for contact and tightness
	Air-end failure	Contact a local authorized distributor.
Compressor shuts down during loaded condition	High ambient temperature	Make fresh air intake openings or install ducts to discharge the hot air.
	Low incoming voltage	Check voltage and power source, or contact local power company.
	High operating pressure	Reset, check line pressure and ensure it does not exceed the compressor's maximum operating pressure.
	Low fluid level	Top-up fluid
	PLC controller indicate separator requires maintenance	Replace separator element.
Compressor does not reload when service line pressure drops to reset	Faulty solenoid	Repair or replace as necessary
	Loose wiring connection	Check and tighten wiring terminals
	Jammed air inlet valve assembly	Check and repair air inlet valve
	Faulty air pressure sensor	Repair or replace as necessary

Table 7-1: TROUBLE SHOOTING GUIDE (Continued)		
Symptom	Possible Cause	Solution
High air discharge temperature	Low Fluid Level	Check oil level
	Incorrect fluid brand	Check oil code number, replace as necessary
	High ambient temperature	Check air exhaust, reduce room temperature.
	Clogged oil filter	Change oil filter
	Clogged internal aftercooler	Chemical cleaning for after-cooler
	Dusty after-cooler fins	Chemical wash for after-cooler fins
	Fan motor setting	Adjust
Low air capacity delivery	Temperature sensor failure	Check and replace as necessary
	Clogged air filter	Clean air filter or replace with new element
	Air Intake valve failure	Remove the intake hose and check the inlet valve for proper operation
	Separator failure	Replace separator element
	Faulty solenoid	Repair or replace as necessary
Excessive oil carry over in discharge compressed air.	Faulty safety valve	Repair or replace as necessary
	High oil level	Check oil level
	Clogged oil orifice valve	Clean or replace as necessary
	Low discharge pressure	Adjust
	Air/oil separator element failure	Clean or replace as necessary
Loading function Failure	Minimum pressure valve malfunction	Check for leaking, replace as necessary
	Solenoid valve failure	Check and replace as necessary
	Pipe leak	Check and replace as necessary
	Air Intake valve stuck open	Remove the intake hose and check the inlet valve for proper operation
	Minimum pressure valve failure	Check for leaking, replace as necessary

Table 7-1: TROUBLE SHOOTING GUIDE (Continued)		
Symptom	Possible Cause	Solution
Unloading failure at working pressure, causing safety valve to release pressure	Pressure loading setting	Adjust as necessary
	Solenoid valve failure	Check and replace as necessary
	Clogged air/oil separator	Check and replace as necessary
	Air Intake valve stuck open	Remove the intake hose and check the inlet valve for proper operation
	Safety valve failure	Repair or replace as necessary
	PLC controller failure	Check and replace as necessary
Compressor air discharge pressure below normal operating settings	Clogged air filter	Clean or replace as necessary
	Air Intake valve stuck closed	Remove the intake hose and check the inlet valve for proper operation
	Clogged air/oil separator	Check or replace as necessary
	Solenoid valve failure	Check and replace as necessary
	Safety valve failure	Check and replace as necessary
Short period of load/unload	Pipe leak	Check and replace as necessary
	Pressure setting	Change setting above 1Bar
	Receiver tank too small	Check or increase volume of receiver tank
	Air flow into the main network restricted	Increase pipe size. Checks filter cartridge failure.
Oil vapor leak from air filter when compressor stops	Air inlet valve failure	Check and replace as necessary
	Minimum pressure valve failure	Check for leaks and replace as necessary
	Pressure relief valve failure	Check and replace as necessary



Standard Terms and Conditions

These terms and conditions govern the sale of Products (“Rotary Screw Air Compressors and parts”) and provisions of services by Kaishan Compressor USA Ltd. (Seller) and its authorized representative or buyer. These terms and conditions (“Agreement”) take precedence over Buyer’s supplemental or conflicting terms and conditions to which notice of objection is hereby given. Neither Seller’s commencement of performance or delivery shall be deemed or construed as acceptance of Buyer’s supplemental or conflicting terms and conditions. Kaishan Compressor’s failure to object to conflicting or additional terms will not change or add to the terms of this agreement. Buyer’s acceptance of the Products and/or Services from Seller shall be deemed to constitute acceptance of the terms and conditions contained herein.

Orders: All orders placed by Buyer are subject to acceptance by Seller. Orders may not be canceled or rescheduled without Seller’s written consent. All orders must identify the products, unit quantities, part numbers, applicable prices and requested delivery dates of the Products being purchased. Seller may at its sole discretion allocate Product among its Buyer. Seller may designate certain Products and Services as non-cancelable, non-returnable and the sale of such Products shall be subject to the special terms and conditions contained in Seller’s Customer Acknowledgment or Non-Returnable Product Form, which shall prevail and supersede any inconsistent terms and conditions contained herein or elsewhere.

Prices: The prices of the Products are those prices specified on the front of the invoice or contained within an agreed written contract. Price quotations shall automatically expire in thirty (30) days from the date issued, or as otherwise stated in the quotation.

Taxes: Unless otherwise agreed to in writing by Seller, all prices quoted are exclusive of transportation and insurance costs, duties, and all taxes including federal, state and local sales, excise and value added, goods and services taxes, and any other taxes. Buyer agrees to indemnify and hold Seller harmless for any liability for tax in connection with the sale, as well as the collection or withholding thereof, including penalties and interest thereon. When applicable, transportation and taxes shall appear as separate items on Seller’s invoice.

Payment: Payment may be made by check, money order, credit card, or wire transfer (all fees are borne by the Buyer). Where Seller has extended credit to Buyer, terms of payment shall be net thirty (30) days from date of invoice, without offset or deduction. On any past due invoice, Seller may impose a monthly interest rate. If Buyer fails to make the required payments the Seller will impose the interest rate each month. If Buyer fails to make each payment when it is due, Seller reserves the right to withdraw credit and thereby suspend or cancel performance under any or all purchase orders or agreements in which Seller has extended credit to Buyer. In the event of default by Buyer, Seller shall be entitled to costs, fees, and expenses including but not limited to recovery of attorney fees, court costs and fees, and collections costs.



Standard Terms and Conditions

Delivery and Title: The locations of shipment delivery will be made according to the Seller and Buyer agreement. Title and risk of loss pass to the Buyer upon delivery of the Product to the carrier. Seller's delivery dates are estimates only and Seller is not liable for delays in delivery or for failure to perform due to causes beyond the reasonable control of the Seller, nor shall the carrier be deemed an agent of the Seller. A delayed delivery of any part of an Order does not entitle Buyer to cancel other deliveries. Kaishan Compressor will comply with various federal, state and local laws and regulation concerning occupational health, safety and environment concerns. Buyer has full responsibility to comply with those laws and regulations during the installation and operation of the equipment.

Acceptance / Returns: Shipments will be deemed to have been accepted by Buyer upon delivery of the said shipments to Buyer unless rejected upon receipt. Buyer shall perform all inspections and tests. Buyer deems necessary as promptly as possible but in no event later than 7 days after receipt of Products, at which time Buyer will be deemed to have irrevocably accepted the Products. Any discrepancy in shipment quantity must be reported within 7 days after receipt of Products. Buyer may not return Products without a Return Material Authorization ("RMA") number. RMA's valid for 30 days from the date issued.

Standard Warranty: Buyer will honor Product warranties and indemnities authorized by the manufacturer, including any transferable. 90 days warranty is given for service parts from receipt date. Seller warrants to Buyer that Products purchased hereunder will conform to the applicable manufacturer's specifications for such products and that any value-added work performed by Seller on such Products will conform to applicable Buyer's specifications. If Seller breaches this warranty, Buyer's remedy is limited to (at Seller's election) (1) refund of Buyer's purchase price for such Product (without interest), (2) repair of such Products, or (3) replacement of such Products provided that such Products must be returned to Seller, along with acceptable evidence of purchase within 13 days from date of delivery, transportation charges prepaid. No warranty will apply if the Product has been subject to misuse, neglect, accident or modification.

Limitation of Liabilities: Buyer shall not be entitled to, and Seller shall not be liable for, loss of profit or revenue, promotional or manufacturing expenses, overheads expenses, business interruption cost, loss of data, removal or reinstallation costs, injury to reputation of buyer, punitive damages, loss of contractor orders or any indirect, special, incidental or consequential damages of any nature. Buyer's recovery from seller for any claim shall not exceed the purchase price paid for the affected products irrespective of the nature of the claim whether in contract, tort, warranty, or otherwise. Buyer will indemnify, defend and hold seller harmless from any claims based on (a) Seller's compliance with buyer's designs, specifications, or instructions, (b) Modification of any products by anyone other than Seller, or (c) use in combination with other products not supplied by seller.

Standard Terms and Conditions

Use of Products: Unless otherwise specified. Products sold by Seller are not designed, intended or authorized for use in life support, life sustaining, nuclear, or other applications in which the failure of such Products could reasonably be expected to result in personal injury, loss of life or catastrophic property damage. If buyer uses or sales the Products for use in any such applications: (1) Buyer acknowledges that such use or sale is at Buyer's sole risk; (2) Buyer agrees that Seller and the manufacturer of the Products are not liable, in whole or in part, for any claim or damage arising from such use; and (3) Buyer agrees to indemnify, defend and hold Seller and the manufacturer of the Products harmless from and against any and all claims, damages, losses, costs, expenses and liabilities arising out of or in connection with such use or sale.

Force Majeure: Seller is not liable for failure to fulfill its obligations for any accepted Order or for delays in delivery due to causes beyond Seller's reasonable control including, but not limited to, acts of God, natural or artificial disaster, riot, war, strike, delay by carrier, shortage of Product, acts or omissions of other parties, acts or omissions of civil or military authority, Government priorities, changes in law, material shortages, fire, strikes, floods, epidemics, quarantine restrictions, acts of terrorism, delays in transportation or inability to obtain labor, materials or products through its regular sources, which shall be considered as an event of force majeure excusing Seller from performance and barring remedies for non- performance. In an event of force majeure condition, the Seller's time for performance shall be extended for a period equal to the time lost as a consequence of the force majeure condition without subjecting Seller to any liability or penalty. Seller may, at its option, cancel the remaining performance, without any liability or penalty, by giving notice of such cancellation to the Buyer.

General: (a) Seller will comply with state law for any dispute from buyer. (b) Buyer may not assign this Agreement without the prior written consent of Seller. Seller or its affiliates may perform the obligations under this Agreement. This Agreement is binding on successor and assigns, (c) Products, including software or other intellectual property, are subject to any applicable rights of third parties, such as patents, copyrights and/or user licenses.



Contact Information

Kaishan Compressor, LLC.,

Add.: 15445 Industrial Park Dr., Loxley, AL, Post code: 36551

Office number: +1 251-202-0577

www.KaishanUSA.com